

RAMOTSHERE MOILOA LOCAL MUNICIPALITY



(In terms of the Supply Chain Management Regulations (Government Gazette 27636 of 30 May 2005))

BID NO: RMLM SCM:2025/2026:COMM-05B: APPOINTMENT OF A GENERAL BUILDING CONTRACTOR CIDB GRADING 3GB OR HIGHER FOR SUPPLY, DELIVERY AND INSTALLATION OF CONCRETE PALISADE FENCE AND A STEEL GATE AT IKAGELENG CEMETERY.

Closing Date and Time: Thursday, 05th of February 2026

NAME OF BIDDER:		Bidder VAT registered?
TOTAL BID PRICE (INCL VAT): (Brought forward from MBD 3.1)		Yes: <input type="checkbox"/> No: <input type="checkbox"/>

Please note that it is compulsory for all service providers to complete the above required information

CONTENTS

1. BID CHECKLIST	1
2. SPECIAL CONDITIONS OF BID	2
3. EVALUATION	3
4. BID DECLARATION.....	4
5. RESOLUTION TAKEN BY THE BOARD OF DIRECTORS / MEMBERS / PARTNERS	5
6. RESOLUTION TAKEN BY THE BOARD OF DIRECTORS OF A CONSORTIUM OR JOINT VENTURE..	6
7. INVITATION TO BID (MBD 1)	7
8. TAX CLEARANCE REQUIREMENTS (MBD 2)	9
9. PRICING SCHEDULE – FIRM PRICES (MBD 3.1).....	15
10. PREVIOUS WORK EXPERIENCE OF A SIMILAR NATURE	21
11. DECLARATION OF INTEREST (MBD 4)	23
12. DECLARATION FOR PROCUREMENT ABOVE R10 MILLION (ALL APPLICABLE TAXES INCLUDED) (MBD 5).....	25
13. PREFERENCE POINTS CLAIM FORM IN TERMS OF THE PREFERENTIAL PROCUREMENT REGULATIONS 2011 (MBD 6.1).....	27
14. DECLARATION OF BIDDER’S PAST SUPPLY CHAIN MANAGEMENT PRACTICES (MBD 8)	30
15. CERTIFICATE OF INDEPENDENT BID DETERMINATION (MBD 9)	25
16. ANNEXURE A: GOVERNMENT PROCUREMENT: GENERAL CONDITIONS OF CONTRACT (JULY 2010)	27

Tender Description	Tender number	The specific goals allocated points in terms of this tender	Number of points allocated (80/20 system)
<p>APPOINTMENT OF A GENERAL BUILDING CONTRACTOR CIDB GRADING 3GB OR HIGHER FOR SUPPLY, DELIVERY AND INSTALLATION OF CONCRETE PALISADE FENCE AND A STEEL GATE AT IKAGELENG CEMETERY.</p>	<p>RMLM SCM : 2025/2026-COMM 05B</p>	Locality	4
		Gender	4
		Disability	4
		Youth	4
		Nationality	4
<p>EVALUATION CRITERIA</p> <ul style="list-style-type: none"> • FINANCIAL RISK RATING 20 • SIMILAR PROJECTS COMPLETED 50 • PROJECT TEAM 30 <p>(For a bidder to qualify it is a requirement to score a minimum of 70 points out of a maximum of 100 points for functionality)</p>	<p>SPECIFICATION</p> <p>APPOINTMENT OF A GENERAL BUILDING CONTRACTOR CIDB GRADING 3GB OR HIGHER FOR SUPPLY, DELIVERY AND INSTALLATION OF CONCRETE PALISADE FENCE AND A STEEL GATE AT IKAGELENG CEMETERY.</p> <p>(More detailed specifications will be in outlined on the tender document.)</p>	<p>Tender Documents are obtainable from the E-Tender portal at www.etenders.gov.za OR Municipal_website at www.ramotshere.gov.za free of charge.</p>	

COMPULSORY BRIEFING SESSION: 14 JANUARY 2026 (Wednesday) @10:00 VENUE: COUNCIL CHAMBER

Tenders/Proposals will be evaluated and adjudicated in accordance with the Ramotshere Moiloa Local Municipality Management Policy and the Preferential Procurement Policy Framework Act No.5 of 2000, using the 80/20 points system of which 80 points will be allocated for price and 20 points will be allocated for specific goals as determined by the Preferential Procurement Policy. Validity period for this tender will be 90 days.

Duly completed Tenders/Proposals must be attached with the following documents:

NB: FAILURE TO ATTACH THE BELOW DOCUMENTS WILL LEAD TO DISQUALIFICATION OF BIDS

- Copies of cc/co registration certificates;
- Company Profile
- Certified copy of Identity document of Director(s)/Shareholders not older than three months
- Tax Compliance status pin of the Company.
- CSD Report
- A letter confirming bank details of the company not older than 3 Months
- Proof of Municipal rates/ letter from Tribal Authority/ copy of a valid lease agreement for the Company
- In case of Joint Venture must submit a Joint Venture agreement should be attached(sworn affidavit not acceptable)
- CIBD Grading 3GB or higher
- Valid COIDA

Duly completed tender/proposal clearly marked with bid number should be submitted in the tender box on the ground floor of Ramotshere Moiloa Local Municipality offices, Cnr Coetzee and President STR, Zeerust not later than **Thursday, 05th February 2026 at 11h00 as per dates indicated above, thereafter tenders will be opened in public and it is recommended that all bidders must attend.**

Please note that no late, electronic or faxed proposals will be accepted. Documents sent by Courier Company must be deposited in the tender box by the courier company on or before the closing date and time. No documents will be received by the staff from any courier company. The Council is not bound to accept lowest or any proposal and reserves its rights in this regard.

Mr L. I. Mokgatlhe
Municipal Manager

1. BID CHECKLIST

Bidders are to use this checklist to ensure that the bid documentation is complete for administrative compliance. The bidder is to indicate that the documentation is complete and included in the bid document by completing the table below.

Tick to indicate that the information is included

Item	Description	Yes	No	n/a
1.	Is your business registered as accredited prospective supplier with Ramotshere Moiloa Local Municipality?	<input type="checkbox"/>	<input type="checkbox"/>	<input type="checkbox"/>
2.	Is the bid document administration fee paid and a copy of the receipt attached to the bid document?	<input type="checkbox"/>	<input type="checkbox"/>	<input type="checkbox"/>
3.	Did you read and understand all pages of the bid document?	<input type="checkbox"/>	<input type="checkbox"/>	<input type="checkbox"/>
4.	Did you complete the bid documents in black ink?	<input type="checkbox"/>	<input type="checkbox"/>	<input type="checkbox"/>
5.	Did you provide a certified copy of your company registration and VAT registration certificates?	<input type="checkbox"/>	<input type="checkbox"/>	<input type="checkbox"/>
6.	Did you provide a certified copy of your identity document in case of sole proprietorship?	<input type="checkbox"/>	<input type="checkbox"/>	<input type="checkbox"/>
7.	Did you provide an original and valid CIDB registration certificate or a certified copy thereof, if applicable.	<input type="checkbox"/>	<input type="checkbox"/>	<input type="checkbox"/>
8.	Did you provide registration certificate pertaining to the relevant industry e.g. (Electrical Contractors Board), if applicable?	<input type="checkbox"/>	<input type="checkbox"/>	<input type="checkbox"/>
9.	Did you provide a covering letter?	<input type="checkbox"/>	<input type="checkbox"/>	<input type="checkbox"/>
10.	Did you provide an original and valid tax clearance certificate? (MBD2)	<input type="checkbox"/>	<input type="checkbox"/>	<input type="checkbox"/>
11.	Did you complete and sign the Bid Declaration Form? (section 3)	<input type="checkbox"/>	<input type="checkbox"/>	<input type="checkbox"/>
12.	Where applicable, is the resolution taken the Board of Directors/Members/Partners completed and signed? (section 4)	<input type="checkbox"/>	<input type="checkbox"/>	<input type="checkbox"/>
13.	Where applicable, is the resolution taken the Board of Directors of a Consortium or Joint Venture completed and signed? (section 5)	<input type="checkbox"/>	<input type="checkbox"/>	<input type="checkbox"/>
14.	Is invitation to bid completed and signed?(MBD 1)	<input type="checkbox"/>	<input type="checkbox"/>	<input type="checkbox"/>
15.	Is the Declaration of Interest completed and signed? (MBD 4)	<input type="checkbox"/>	<input type="checkbox"/>	<input type="checkbox"/>
16.	Is the Declaration of Bidder's Past Supply Management Practices completed and signed? (MBD 8)	<input type="checkbox"/>	<input type="checkbox"/>	<input type="checkbox"/>
17.	Is the Certificate of Independent Bid Determination completed and signed? (MBD 9)	<input type="checkbox"/>	<input type="checkbox"/>	<input type="checkbox"/>
18.	Did you complete and sign the Previous Work Experience of a Similar Nature section? (section 9)	<input type="checkbox"/>	<input type="checkbox"/>	<input type="checkbox"/>
19.	Is the Preference Points Claim Form in Terms of the Preferential Procurement Regulation 2011 completed and signed? (MBD 6.1)	<input type="checkbox"/>	<input type="checkbox"/>	<input type="checkbox"/>
20.	Did you provide an original and valid B-BBEE status level verification certificate or a certified copy thereof or, if you qualify as an EME, did you provide a verification certificate? (MBD 6.1)	<input type="checkbox"/>	<input type="checkbox"/>	<input type="checkbox"/>
21.	Does the product/service offered conform to the Bid Specifications?	<input type="checkbox"/>	<input type="checkbox"/>	<input type="checkbox"/>

22.	Is Pricing Schedule completed?(MBD 3.1)	<input type="checkbox"/>	<input type="checkbox"/>	<input type="checkbox"/>
23.	Where applicable, is the Declaration for Procurement Above R10 million (all applicable taxes included) completed and signed? (MBD 5)	<input type="checkbox"/>	<input type="checkbox"/>	<input type="checkbox"/>
24.	Did you attach the annual financial statements as required in MBD 5 ? (For Procurements above R10 million)	<input type="checkbox"/>	<input type="checkbox"/>	<input type="checkbox"/>

2. SPECIAL CONDITIONS OF BID

1. The Municipality's document must be kept as supplied and submitted with all schedules / forms fully completed.
2. Any other documents, certificates etc. must be attached as an annexure to the official Municipal document.
3. Where the Municipality's official document is taken apart and not submitted as supplied, the bid might be rejected.
4. Schedules / forms not duly completed and signed by the bidder will result in a bid not being considered.
5. All Forms of Special Conditions in Specifications should be included.
6. The bid document must be completed in black ink, and prices must be VAT inclusive, unless otherwise specified.
7. The lowest or any Bid will not be necessarily be accepted, and the Ramotshere Moiloa Local Municipality reserves the right to accept the whole or any portion of a Bid.
8. All prices and details must be legible to ensure the bid will be considered for adjudication.
9. Corrections may not be made by means of correction fluid such as Tip – Ex, or any other similar product. In the event of a mistake being made, it should be crossed out in ink and be accompanied by a full signature at each and every alteration. The Municipality reserves the right to reject the bid if corrections are not made in accordance with the above.
10. All bid documents must include the following documents:
 - Copies of Company registration certificate,
 - Company profile
 - Certified ID copy(s) of Director(s)/Shareholder(s) not older than three months,
 - Original proof of purchase of tender document,
 - Tax compliance status pin of the company,
 - CSD registration report,
 - A letter confirming bank details of the company not older than 3 months,
 - Proof of Municipal rates/letter from Tribal Authority / Copy of a valid lease agreement for the company,
 - In case of a joint venture a joint venture agreement should be attached (sworn affidavit is not acceptable),
 - Authority of signatories,
 - Valid COIDA,
 - CIDB Contractor grading of 3GB and higher
11. The bidder may submit a comprehensive company profile, for example the founding company statements, as well as a detailed exposition of previous work done.
12. Bidders are required to be registered on the Ramotshere Moiloa Local Municipality Supplier Database. Service Providers are required to be registered on the Municipality's data base (Application forms are obtainable from the Finance Department of the Municipality).

13. No bid forwarded by e – mail, telegram, telex, facsimile or similar apparatus will be considered.
14. Late bids shall not be admitted for consideration.
15. Bids must be properly received and deposited in the bid box of Ramotshere Moiloa Local Municipality on or before :. Bid offers must be submitted in a sealed envelope properly marked in terms of the bid number and bid description, at the offices of the Municipality situated in Cnr Coetzee and President str, Zeerust
16. Copyright / Patent Rights – Copyright in any document produced, and the patent rights or ownership in any plant, machinery, thing, system or process designed or devised, by a consultant in the course of the consultancy service is vested in the Ramotshere Moiloa Local Municipality.
17. It is compulsory for Bidders to be registered with the CIDB. Only bids from Bidders who have a CIDB contractor grading designation of **3GB** and higher will be considered.

3. EVALUATION

The following evaluation method will be used:

1. After the closing date of the bid invitation, an appointed evaluation committee of Ramotshere Moiloa Local Municipality officials and possibly other external parties will evaluate the proposals of the bidders.
2. The committee will individually evaluate each of the bids received against the appointed criteria as provided for in Preferential Procurement Policy Framework Act of 2005 (as amended).

All bids submitted will be evaluated for Functionality only.

Bids will be evaluated in accordance with the preferential procurement Policy Framework Act (PPPFA), using the 80/20 split.

The assessment of functionality will be done in terms of the evaluation criteria and the minimum threshold value of 70 points. A bid will be disqualified if it fails to meet the minimum threshold value for functionality as per the bid invitation.

For functionality, the following criteria will be applicable and the maximum value of points breakdown for each criterion using these scale level descriptors:

Point's breakdown:

Functionality Table

CRITERIA	POINTS	
	MAX	
FINANCIAL RISK RATING	20	
Bank Rating D	5	
Bank Rating C	10	
Bank Rating B	15	
Bank Rating A	20	
SIMILAR PROJECTS COMPLETED (ATTACH APPOINTMENT LETTERS & COMPLETION CERTIFICATE)	50	
Completed 1 project	10	
Completed 2 projects	30	
Completed 3 or More	50	

PROJECT TEAM	30	
Site Manager (min National Diploma/N6 in construction/civil)	10	
Foreman at least 5 Years' Experience and relevant qualifications in Construction	10	
At least one team member with NQF level 5 qualification in LIC	10	
GRAND TOTALS (POINTS)	100	

4. BID DECLARATION

1. I/we Mr/Mrs/Messrs _____ duly assigned to represent the bidder for the purpose of this bid, hereby bid to supply the goods and/or render services described in the attached documents to the Ramotshere Moiloa Local Municipality on terms and conditions stipulated in this bid and in accordance with the specifications stipulated in the bid documents (which shall be taken as part of, and incorporated into this bid) at the prices reflected in the Pricing Schedule.
2. I/we agree that this offer shall remain valid for a period of **90** days commencing from the closing date and time of this bid.
3. I/We further agree that:
 - 3.1 This bid and its acceptance shall be subject to the terms and conditions contained in the in the Ramotshere Moiloa Local Municipality Supply Chain Management Policy;
 - 3.2 if I/we withdraw my/our bid within the period for which I/we have agreed that the bid shall remain open for acceptance, or fail to fulfil the contract when called upon to do so, Ramotshere Moiloa Local Municipality may, without prejudice to its other rights, agree to the withdrawal of my/our bid or cancel the contract that may have been entered into between me/us and the Ramotshere Moiloa Local Municipality and I/we will then pay to Ramotshere Moiloa Local Municipality any additional expense incurred by the Ramotshere Moiloa Local Municipality having either to accept any less favourable bid or, if fresh bids have to be invited, the additional expenditure incurred by the invitation of fresh bids and by the subsequent acceptance of any less favourable bid; the Ramotshere Moiloa Local Municipality shall also have the right to recover such additional expenditure by set-off against moneys which may be due or become due to me/us under this or any other bid or contract or against any guarantee or deposit that may have been furnished by me/us or on my/our behalf for the due fulfilment of this or any other bid or contract and pending the ascertainment of the amount of such additional expenditure to retain such moneys, guarantee or deposit as security for any loss the Ramotshere Moiloa Local Municipality may sustain by reason of my/our default;
 - 3.3 If my/our bid is accepted the acceptance may be communicated to me/us by letter or order by certified mail or registered mail. Such posting shall be deemed to be proper service of such notice with effect from the date of posting/dispatch of such notice;
 - 3.4 The law of the Republic of South Africa shall govern the contract created by the acceptance of my/our bid and that I/we choose *domicilium citandi et executandi* in the Republic of South Africa, where any and all legal notices may be served at (full street address of this place):

4. I/we furthermore confirm that I/we have satisfied myself/ourselves as to the correctness and validity of my/our bid; that the price(s) and rate(s) quoted cover all the work/item(s) specified in the bid documents and that the price(s) and rate(s) cover all my/our obligations under a resulting contract and that I/we accept that any mistakes regarding price(s) and calculations will be at my/our risk.
5. I/we hereby accept full responsibility for the proper execution and fulfilment of all obligations and conditions devolving on me/us under this agreement as the Principal(s) liable for the due fulfilment of this contract.
6. I/we agree that any action arising from this contract may in all respects be instituted against me/us and I/we hereby undertake to satisfy fully any sentence or judgment which may be pronounced against me/us as a result of such action.
7. I/we declare that I/we have participation/no participation* in the submission of any other offer for the supplies/services described in the attached documents. *If in the affirmative, state name(s) of bid(s) involved.

Name of Bidder: _____ Signature _____

5. RESOLUTION TAKEN BY THE BOARD OF DIRECTORS / MEMBERS / PARTNERS

RESOLUTION of a meeting of the Board of Directors / Members / Partners of

(Name of Bidder)

Held at _____ On _____

(Place)

(Date)

RESOLVED THAT:

1. The enterprise submits a Bid to the Ramotshere Moiloa Local Municipality in respect of the following project:

RMLM SCM:2025/2026:COMM-05B APPOINTMENT OF A GENERAL BUILDING CONTRACTOR
CIDB GRADING 3GB OR HIGHER FOR SUPPLY, DELIVERY AND INSTALLATION OF CONCRETE
PALISADE FENCE AND A STEEL GATE AT IKAGELING CEMETERY.

2. Mr/Mrs/Ms _____

In _____ and who will
his/her capacity as sign as
follows:

(Specimen Signature)

be, and is hereby, authorised to sign the Bid and/or all other documents and/or correspondence in connection with and relating to the Bid, as well as to sign any contract, and/or all documentation resulting from the award of the bid to the enterprise mentioned above.

Note: The resolution must be signed by all the directors or members/partners of the bidding enterprise. Should the space provided below not be sufficient for all directors to sign, please provide a separate sheet in the same format as below.

	Name	Capacity	Signature
1			
2			
3			
4			

5			
6			

Enterprise Stamp

6. RESOLUTION TAKEN BY THE BOARD OF DIRECTORS OF A CONSORTIUM OR JOINT VENTURE

RESOLUTION of a meeting of the Board of Directors / Members / Partners of

(Name of Bidder)

Held at _____ On _____

(Place) (Date)

RESOLVED THAT:

- The enterprise submits a Bid to the Ramotshere Moiloa Local Municipality in respect of the following project:

BID NO: RMLM SCM:2025/2026 APPOINTMENT OF A GENERAL BUILDING CONTRACTOR CIDB GRADING 3GB OR HIGHER FOR SUPPLY, DELIVERY AND INSTALLATION OF CONCRETE PALISADE FENCE AND A STEEL GATE AT IKAGELENG CEMETERY.

As a Consortium/Joint Venture comprising *(list all the legally correct full names and registration numbers, if applicable, of the Enterprises forming the Consortium/Joint Venture)*

(Enterprise full Name and Registration Number)

(Enterprise full Name and Registration Number)

- Mr/Mrs/Ms _____

In _____ and who will
his/her capacity as sign as
follows:

(Specimen Signature)

be, and is hereby, authorised to sign the Bid and/or all other documents and/or correspondence in connection with and relating to the Bid, as well as to sign any contract, and/or all documentation resulting from the award of the Bid to the **Consortium/Joint Venture** enterprise mentioned above.

3. The enterprise in the form of a consortium or joint venture accept jointly and several liability with parties under item 1 above for the fulfilment of the obligations of the joint venture deriving from, and in any way connected with the contract to be entered into with the #Municipality# in respect of the project described above under item 1.
4. The **Consortium/Joint venture** enterprise chooses as its *domicilium citandi et executandi* for all purposes arising from this joint venture agreement and contract with Ramotshere Moiloa Local Municipality in respect of the project under item 1:

(Physical Address)

Note: The resolution must be signed by all the directors or members / partners of the bidding enterprise. Should the space provided below not be sufficient for all directors to sign, please provide a separate sheet in the same format as below.

	Name	Capacity	Signature
1			
2			
3			
4			
5			
6			

Enterprise Stamp

MBD 1

7.

INVITATION TO BID (MBD 1)

YOU ARE HEREBY INVITED TO BID FOR REQUIREMENTS OF RAMOTSHERE MOILOA LOCAL MUNICIPALITY

BID NUMBER:

RMLM SCM:2025/2026:COMM-05B

CLOSING DATE AND TIME:

05th February 2026 at 11H00

BID DESCRIPTION:

BID NO: RMLM SCM:2025/2026: COMM-05 APPOINTMENT OF A GENERAL BUILDING CONTRACTOR CIDB GRADING 3GB OR HIGHER FOR SUPPLY, DELIVERY AND INSTALLATION OF CONCRETE PALISADE FENCE AND A STEEL GATE AT IKAGELENG CEMETERY.

The Successful bidder will be required to fill in and sign a written Contract Form (MDB 7)

NB: A compulsory site inspection and bid briefing meeting with representatives of the Municipality will be held not be held.

NB: Bids must be properly received and deposited in the bid box of Ramotshere Moiloa Local Municipality on or before the closing date and before the closing time. Bid offers must be submitted in a sealed envelope properly marked in terms of the bid number and bid description as indicated above. No bid offers will be accepted via e-mail, facsimile (fax) or telegram.

DEPOSITED IN THE BID BOX SITUATED AT:

Ramotshere Moiloa Local Municipality
Cnr Coetzee and President str,
Zeerust
2865

Bidders should ensure that bids are delivered timeously to the correct address. If the bid is late, it will not be accepted for consideration. The bid box is available during office hours (Monday to Friday, 07H30 to 16H00).

ALL BIDS MUST BE SUBMITTED ON THE OFFICIAL FORMS – (NOT TO BE RE-TYPED)

THIS BID IS SUBJECT TO THE PREFERENTIAL PROCUREMENT POLICY FRAMEWORK ACT AND THE PREFERENTIAL PROCUREMENT REGULATIONS, 2011, THE GENERAL CONDITIONS OF CONTRACT (GCC) AND, IF APPLICABLE, ANY OTHER SPECIAL CONDITIONS OF CONTRACT

NB: NO BIDS WILL BE CONSIDERED FROM PERSONS IN THE SERVICE OF THE STATE (as defined in Regulation 1 of the Local Government: Municipal Supply Chain Management Regulations)

THE FOLLOWING PARTICULARS MUST BE FURNISHED
(FAILURE TO DO SO MAY RESULT IN YOUR BID BEING DISQUALIFIED)

NAME OF BIDDER

POSTAL ADDRESS

STREET ADDRESS

TELEPHONE NUMBER CODE.....NUMBER.....

CELLPHONE NUMBER

FACSIMILE NUMBER CODE.....NUMBER.....

E-MAIL ADDRESS

VAT REGISTRATION NUMBER.....

HAS AN ORIGINAL AND VALID TAX CLEARANCE CERTIFICATE BEEN ATTACHED? (MBD 2) *YES / NO

*Delete if not applicable

HAS A B-BBEE STATUS LEVEL VERIFICATION CERTIFICATE BEEN SUBMITTED? (MBD 6.1)

*YES / NO

*Delete if not applicable

IF YES, WHO WAS THE CERTIFICATE ISSUED BY?

- An accounting officer as contemplated in the Close Corporation Act (CCA)
 - A verification agency accredited by the South African National Accreditation System (SANAS) A registered auditor
- (Tick applicable box)

(A B-BBEE STATUS LEVEL VERIFICATION CERTIFICATE MUST BE SUBMITTED IN ORDER TO QUALIFY FOR PREFERENCE POINTS FOR B-BBEE)

ARE YOU THE ACCREDITED REPRESENTATIVE IN SOUTH AFRICA FOR THE GOODS/SERVICES/WORKS OFFERED?

*YES / NO
* Delete if not applicable
(IF YES ENCLOSE PROOF)

SIGNATURE OF BIDDER

DATE

CAPACITY UNDER WHICH THIS BID IS SIGNED

TOTAL BID PRICE R.....

TOTAL NUMBER OF ITEMS OFFERED

ANY ENQUIRIES REGARDING THE BIDDING PROCEDURE MAY BE DIRECTED TO:

Municipality: Ramotshere Moiloa Local Municipality

Department: Finance

Contact Person: Ms B.C Nkgothoe

email: basetzana.nkgothoe@ramotshere.gov.za

ANY ENQUIRIES REGARDING TECHNICAL INFORMATION MAY BE DIRECTED TO:

Contact Person: Mr Thompson Phakalane OR Ms Boitshoko Madumo

email: thompson.phaks@ramotshere.gov.za OR boitshoko.madumo@ramotshere.gov.za

MBD 2

8. TAX CLEARANCE REQUIREMENTS (MBD 2)

It is a condition of bid that the taxes of the successful bidder must be in order, or that satisfactory arrangements have been made with South African Revenue Service (SARS) to meet the bidder's tax obligations.

- 1 In order to meet this requirement bidders are required to complete in full the attached form TCC 001 "Application for a Tax Clearance Certificate" and submit it to any SARS branch office nationally. The Tax Clearance Certificate Requirements are also applicable to foreign bidders / individuals who wish to submit bids.
- 2 SARS will then furnish the bidder with a Tax Clearance Certificate that will be valid for a period of 1 (one) year from the date of approval.
- 3 The original Tax Clearance Certificate must be submitted together with the bid. Failure to submit the original and valid Tax Clearance Certificate will result in the invalidation of the bid. Certified copies of the Tax Clearance Certificate will not be acceptable.
- 4 In bids where Consortia / Joint Ventures / Sub-contractors are involved, each party must submit a separate Tax Clearance Certificate.
- 5 Copies of the TCC 001 "Application for a Tax Clearance Certificate" form are available from any SARS branch office nationally or on the website www.sars.gov.za.
- 6 Applications for the Tax Clearance Certificates may also be made via eFiling. In order to use this provision, taxpayers will need to register with SARS as eFilers through the website www.sars.gov.za.



Application for a Tax Clearance Certificate

Purpose

Select the applicable optionTenders Good standing

If "Good standing", please state the purpose of this application

Empty text box for purpose of application

Particulars of applicant

Name/Legal name (Initials & Surname or registered name)												
Trading name (if applicable)												
ID/Passport no					Company/Close Corp. registered no							
Income Tax ref no					PAYE ref no	7						
VAT registration no	4				SDL ref no	L						
Customs code					UIF ref no	U						
Telephone no	CODE	NUMBER			Fax no	CODE	NUMBER					
E-mail address												
Physical address												
Postal address												

Particulars of representative (Public Officer/Trustee/Partner)

Surname												
First names												
ID/Passport no					Income Tax ref no							
Telephone no	CODE	NUMBER			Fax no	CODE	NUMBER					
E-mail address												
Physical address												

9. PRICING SCHEDULE – FIRM PRICES (MBD 3.1)

(PURCHASES)

NOTE: ONLY FIRM PRICES WILL BE ACCEPTED. NON-FIRM PRICES (INCLUDING PRICES SUBJECT TO RATES OF NOTE: ONLY FIRM PRICES WILL BE ACCEPTED. NON-FIRM PRICES (INCLUDING PRICES SUBJECT TO RATES OF EXCHANGE VARIATIONS) WILL NOT BE CONSIDERED

IN CASES WHERE DIFFERENT DELIVERY POINTS INFLUENCE THE PRICING, A SEPARATE PRICING SCHEDULE MUST BE SUBMITTED FOR EACH DELIVERY POINT

Name of Bidder:

Bid number:

BID NO: RMLM SCM:2025/2026 COMM -05B Thursday

Closing day and time:

05^h of February 2026 at 11h00

Bid description:

APPOINTMENT OF A GENERAL BUILDING CONTRACTOR CIDB GRADING 3GB OR HIGHER FOR SUPPLY, DELIVERY AND INSTALLATION OF CONCRETE PALISADE FENCE AND A STEEL GATE AT IKAGELENG CEMETERY.

OFFER TO BE VALID FOR 90 DAYS FROM THE CLOSING DATE OF BID.

1. EXECUTIVE SUMMARY

Firm bids are hereby requested from registered and accredited service providers who have a CIDB contractor grading designation of **3GB** or higher for APPOINTMENT OF A GENERAL BUILDING CONTRACTOR CIDB GRADING 3GB OR HIGHER FOR SUPPLY, INSTALLATION OF CONCRETE PALISADE FENCE AND STEEL GATE AT IKAGELENG CEMETERY.

2. PURPOSE

The purpose of the project is to fence the existing cemetery at Ikageleng using concrete palisade fencing. Fencing of the grave yard would address the following challenges:

- Keeping animals away from the grave yard.
- To prevent illegal dumping at the grave yard
- To prevent unauthorised people to enter the grave yard.

3. BACKGROUND

Ikageleng cemetery is not fenced.

4. SCOPE AND PARAMETERS

Radius 1200m

4.1. Construction of a Concrete palisade fence 2.4m high and 120x350m square.

A. Strength

The required concrete compressive strength shall be a minimum of 30 MPa, determined in accordance with SANS 5836.

B. Post

The post to be 3.0m long, to take the horizontal load bearing rails. The back section is 140mm wide tapering to the front to 80mm. The thickness of the post shall be 225mm. Posts shall be spaced at 2.0m centre in a concrete foundation. The top of the post is angled at 45°.

C. Pales/Paling

The pales to be 2.4m long with two 10mm holes to take 8mm carriage type bolts. The back section to be 100mm wide tapering to the front to 80mm. The thickness of the pales shall be 75mm. Pales to be spaced at +/- 200mm centres and a total of 9 pales are installed per 2 meter section. The top and bottom of the pales are angled at 45°.

D. Rails or Crossing Beams

The rails to be 1.98m long with nine x 10mm holes to take carriage 8mm type bolts. The rails shall be 150mm wide and 80mm deep. The rails slide into the posts and are grouted into posts with 2 to 1 sand/cement mix

E. Fasteners

All nuts, bolts and washers used for the erection of the fence are mild steel. Electrogalvanized (zinc and chrome) fasteners can be supplied as alternative (coastal application). All bolts holes are filled with cement mortar and therefore negating the need for electrogalvanized fasteners. The grout comprises a 2 to 1 sand/cement mix.

F. Concrete Footing

Each post should embed in a concrete foundation hole of 450mm x 450mm and a depth of 600mm.

The sizes specified are for firm soils and it may be necessary to increase these sizes for softer yielding soils. Foundation shall be a minimum of 15Mpa at 28 days

Drawings

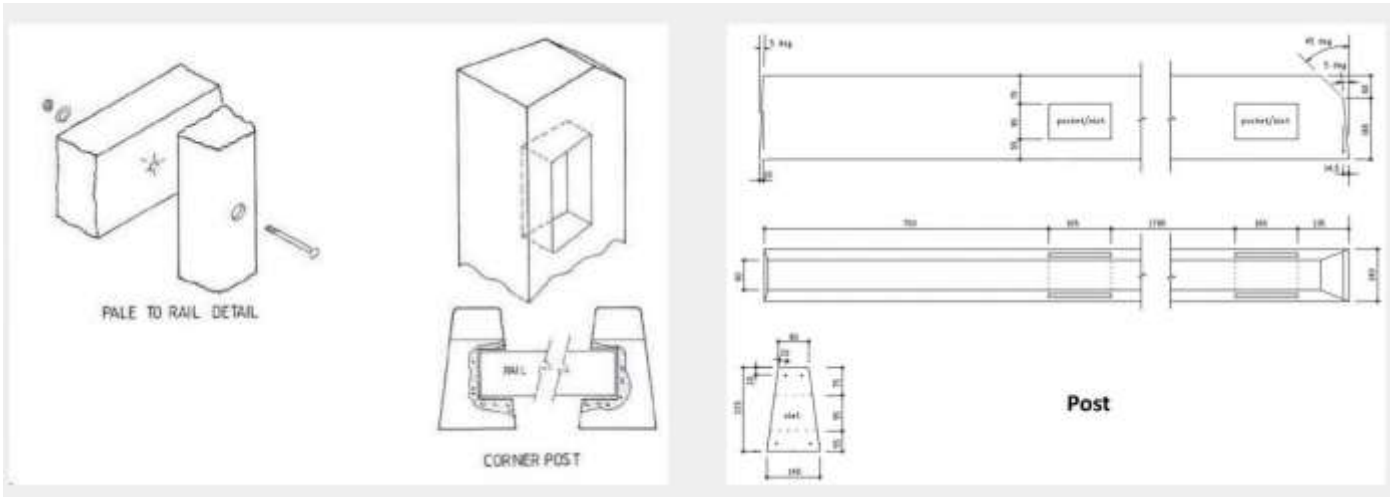
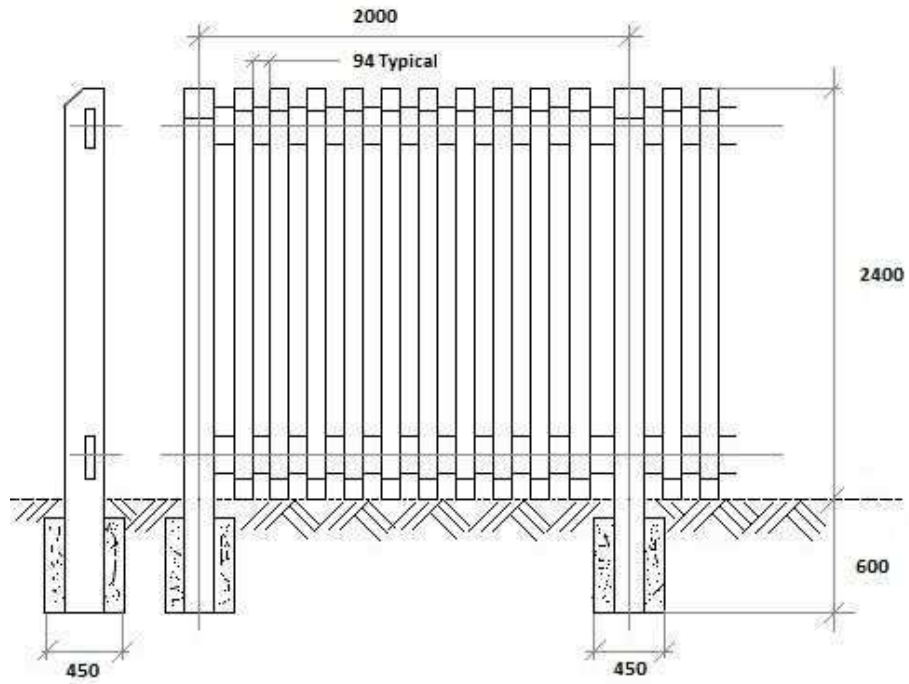

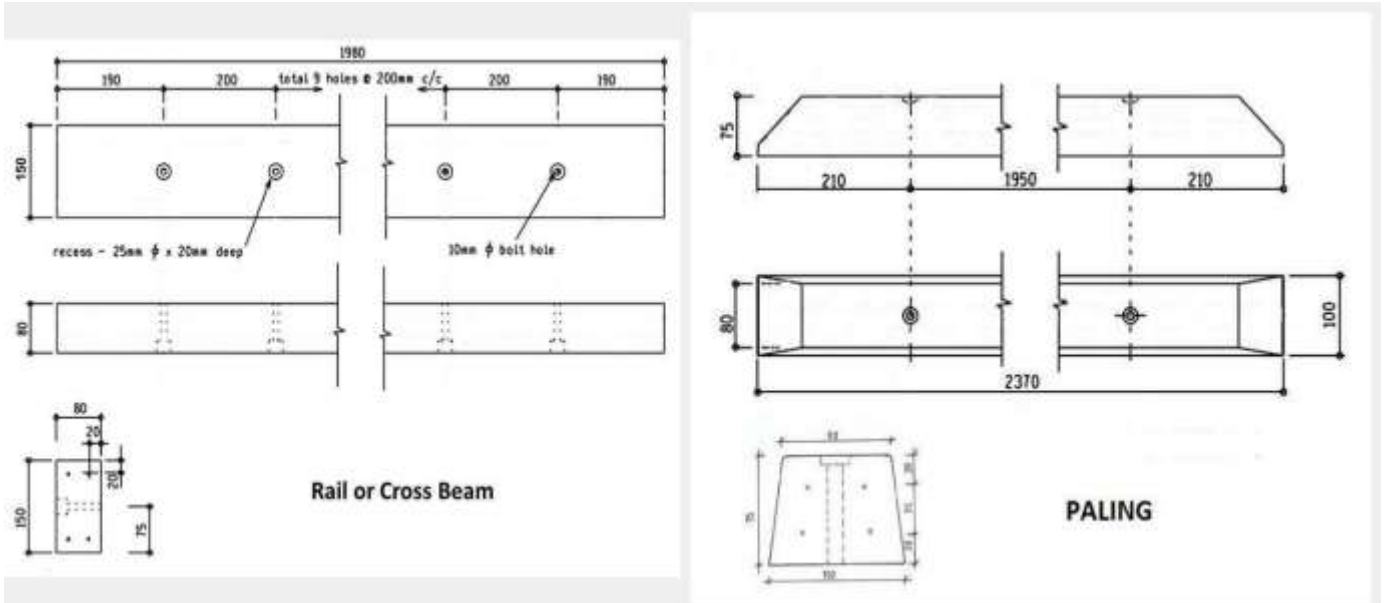

4.2. Sliding Gate

- A. The frame for gates wider than 4000mm X 2.4m using a square tubing of 70mm x 70mm x 2mm.
- B. The gate must be totally closed with a 2mm thick metal sheet
- C. Post for support (typically 76mm x 76mm or 100mm x 100mm square tube dimensions suffice). The post is sunk in concrete to a depth of approximately 500mm below the surface.

5. BILL OF QUANTITIES

The bill of quantities is attached

6. PRICING SCHEDULE / SUMMARIZED BILL OF QUANTITIES

Item No.	Quantity	Description of Goods / services required	Bid Price in RSA Currency (all applicable taxes included**)
1		Preliminary and General	
2		Construction Cost	
3		10% Contingencies	
		Nett price (Excluding VAT)	
		VAT	
		Total bid price (Including VAT) (Carry forward to front cover of this bid document)	

Required by:

At:

Does offer comply with the specifications?

*YES / NO

*Delete if not applicable

If not to specification, indicate deviation(s):

.....

Period required for delivery:

*Delivery: Firm/not firm

*Delete if not applicable

Delivery basis:

Note: All delivery costs must be included in the bid price, for delivery at the prescribed destination.

** "all applicable taxes" includes value-added tax, pay as you earn, income tax, unemployment insurance fund contributions and skills development levies.

10. PREVIOUS WORK EXPERIENCE OF A SIMILAR NATURE

List main work experience of a **similar nature to this bid** successfully executed and completed (or on-going) in the last five (5) years:

No	Institution / client / employer	Project description	Date started	Date completed (indicate projected completion if on-going)	Project value in Rand	Name and contact details of contact person / reference at institution
1						
2						
3						
4						
5						
6						
7						
8						
9						
10						

Representatives of the #Municipality# are hereby authorized to contact the above contact persons / references of the various institutions to verify the correctness of the information as supplied.

..... Signature Date
..... Position Name of Bidder

11. DECLARATION OF INTEREST (MBD 4)

1. **No bid will be accepted from persons in the service of the state*.**
2. Any person, having a kinship with persons in the service of the state, including a blood relationship, may make an offer or offers in terms of this invitation to bid. In view of possible allegations of favouritism, should the resulting bid, or part thereof, be awarded to persons connected with or related to persons in service of the state, it is required that the bidder or their authorised representative declare their position in relation to the evaluating/adjudicating authority and/or take an oath declaring his/her interest.
3. In order to give effect to the above, the following questionnaire must be completed and submitted with the bid:

3.1 Full Name:

3.2 Identity Number:

3.3 Company Registration Number:

3.4 Tax Reference Number:

3.5 VAT Registration Number:

3.6 Are you presently in the service of the state *YES / NO * Delete if not applicable
 3.6.1 If so, furnish particulars.

.....

3.7 Have you been in the service of the state for the past twelve months *YES / NO * Delete if not applicable
 3.7.1 If so, furnish particulars.

.....

3.8 Do you have any relationship (family, friend, other) with persons in the service of the state and who may be involved with the evaluation and or adjudication of this bid? *YES / NO * Delete if not applicable

3.8.1 If so, furnish particulars.

.....

3.9 Are you aware of any relationship (family, friend, other) between a bidder and any persons in the service of the state who may be involved with the evaluation and or adjudication of this bid *YES / NO * Delete if not applicable

3.9.1 If so, furnish particulars

.....

.....

□ MSCM Regulations: "in the service of the state" means to be –

- (a) a member of –
 - (i) any municipal council;
 - (ii) any provincial legislature; or
 - (iii) the national Assembly or the national Council of provinces;
- (b) a member of the board of directors of any municipal entity;
- (c) an official of any municipality or municipal entity;
- (d) an employee of any national or provincial department, national or provincial public entity or constitutional institution within the meaning of the Public Finance Management Act, 1999 (Act No. 1 of 1999);
- (e) a member of the accounting authority of any national or provincial public entity; or (f) an employee of Parliament or a provincial legislature.

3.10 Are any of the company's directors, managers, principal shareholders or stakeholders in service of the state? *YES / NO
* Delete if not applicable

3.10.1 If so, furnish particulars.

.....
.....

3.11 Are any spouse, child or parent of the company's directors, managers, principal shareholders or stakeholders in service of the state? *YES / NO
* Delete if not applicable

3.11.1 If so, furnish particulars.

.....
.....

CERTIFICATION

I, THE UNDERSIGNED (NAME)

CERTIFY THAT THE INFORMATION FURNISHED ON THIS DECLARATION FORM IS CORRECT.

I ACCEPT THAT THE STATE MAY ACT AGAINST ME SHOULD THIS DECLARATION PROVE TO BE FALSE.

.....

Signature	Date
..... Position Name of Bidder

MBD 5

12. DECLARATION FOR PROCUREMENT ABOVE R10 MILLION (ALL APPLICABLE TAXES INCLUDED) (MBD 5)

For all procurement expected to exceed R10 million (all applicable taxes included), bidders must complete the following questionnaire:

1. Are you by law required to prepare annual financial statements for auditing? *YES / NO

* Delete if not applicable

1.1 If yes, submit audited annual financial statements for the past three years or since the date of establishment if established during the past three years.

.....

.....
2. Do you have any outstanding undisputed commitments for municipal services towards any municipality for more than three months or any other service provider in respect of which payment is overdue for more than 30 days? *YES / NO

* Delete if not applicable

2.1 If no, this serves to certify that the bidder has no undisputed commitments for municipal services towards any municipality for more than three months or other service provider in respect of which payment is overdue for more than 30 days.

2.2 If yes, provide particulars.

.....

.....

.....

.....
3. Has any contract been awarded to you by an organ of state during the past five years, including particulars of any material non-compliance or dispute concerning the execution of such contract? *YES / NO

* Delete if not applicable

3.1.1 If yes, furnish particulars

.....

.....

.....

.....

4 Will any portion of goods or services be sourced from outside the Republic, and, if so, what portion and whether any portion of payment from the municipality / municipal entity is expected to be transferred out of the Republic? *YES / NO

* Delete if not applicable

4.1 If yes, furnish particulars

.....
.....
.....
.....

CERTIFICATION

I, THE UNDERSIGNED (NAME)

CERTIFY THAT THE INFORMATION FURNISHED ON THIS DECLARATION FORM IS CORRECT.

I ACCEPT THAT THE STATE MAY ACT AGAINST ME SHOULD THIS DECLARATION PROVE TO BE FALSE.

..... Signature Date
..... Position Name of Bidder

13. PREFERENCE POINTS CLAIM FORM IN TERMS OF THE PREFERENTIAL PROCUREMENT REGULATIONS 2022 (MBD 6.1)

This preference form must form part of all tenders invited. It contains general information and serves as a claim form for preference points for specific goals.

NB: BEFORE COMPLETING THIS FORM, TENDERERS MUST STUDY THE GENERAL CONDITIONS, DEFINITIONS AND DIRECTIVES APPLICABLE IN RESPECT OF THE TENDER AND PREFERENTIAL PROCUREMENT REGULATIONS, 2022

1. GENERAL CONDITIONS

1.1.1 The following preference point systems are applicable to invitations to tender:

- the 80/20 system for requirements with a Rand value of up to R50 000 000 (all applicable taxes included); and
- the 90/10 system for requirements with a Rand value above R50 000 000 (all applicable taxes included).

1.2 To be completed by the organ of state

(a) The applicable preference point system for this tender is the 80/20 preference point system.

(b) 80/20 preference point system will be applicable in this tender. The lowest/ highest acceptable tender will be used to determine the accurate system once tenders are received.

1.3 Points for this tender (even in the case of a tender for income-generating contracts) shall be awarded for: (a) Price; and

(b) Specific Goals.

1.4 To be completed by the organ of state:

The maximum points for this tender are allocated as follows:

	POINTS
PRICE	80
SPECIFIC GOALS	20
Total points for Price and SPECIFIC GOALS	100

1.5 Failure on the part of a tenderer to submit proof or documentation required in terms of this tender to claim points for specific goals with the tender, will be interpreted to mean that preference points for specific goals are not claimed.

1.6 The organ of state reserves the right to require of a tenderer, either before a tender is adjudicated or at any time subsequently, to substantiate any claim in regard to preferences, in any manner required by the organ of state.

2. DEFINITIONS

- (a) “tender” means a written offer in the form determined by an organ of state in response to an invitation to provide goods or services through price quotations, competitive tendering process or any other method envisaged in legislation;

- (b) “**price**” means an amount of money tendered for goods or services, and includes all applicable taxes less all unconditional discounts;
- (c) “**rand value**” means the total estimated value of a contract in Rand, calculated at the time of bid invitation, and includes all applicable taxes;
- (d) “**tender for income-generating contracts**” means a written offer in the form determined by an organ of state in response to an invitation for the origination of income-generating contracts through any method envisaged in legislation that will result in a legal agreement between the organ of state and a third party that produces revenue for the organ of state, and includes, but is not limited to, leasing and disposal of assets and concession contracts, excluding direct sales and disposal of assets through public auctions; and
- (e) “**the Act**” means the Preferential Procurement Policy Framework Act, 2000 (Act No. 5 of 2000).

3. FORMULAE FOR PROCUREMENT OF GOODS AND SERVICES

3.1. POINTS AWARDED FOR PRICE

3.1.1 THE 80/20 OR 90/10 PREFERENCE POINT SYSTEMS

A maximum of 80 or 90 points is allocated for price on the following basis:

$$\begin{array}{ccc}
 \mathbf{80/20} & \mathbf{or} & \mathbf{90/10} \\
 \\
 \mathbf{Ps} = \mathbf{80} \left(\mathbf{1} - \frac{\mathbf{Pt} - \mathbf{Pmin}}{\mathbf{Pmin}} \right)_{\mathbf{or}} & & \mathbf{Ps} = \mathbf{90} \left(\mathbf{1} - \frac{\mathbf{Pt} - \mathbf{Pmin}}{\mathbf{Pmin}} \right)
 \end{array}$$

Where

- Ps = Points scored for price of tender under consideration
- Pt = Price of tender under consideration
- Pmin = Price of lowest acceptable tender

3.2. FORMULAE FOR DISPOSAL OR LEASING OF STATE ASSETS AND INCOME GENERATING PROCUREMENT

3.2.1. POINTS AWARDED FOR PRICE

A maximum of 80 or 90 points is allocated for price on the following basis:

$$\begin{array}{ccc}
 \mathbf{80/20} & \mathbf{or} & \mathbf{90/10} \\
 \\
 \mathbf{Ps} = \mathbf{80} \left(\mathbf{1} + \frac{\mathbf{Pt} - \mathbf{Pmax}}{\mathbf{Pmax}} \right)_{\mathbf{or}} & & \mathbf{Ps} = \mathbf{90} \left(\mathbf{1} + \frac{\mathbf{Pt} - \mathbf{Pmax}}{\mathbf{Pmax}} \right)
 \end{array}$$

Where

- Ps = Points scored for price of tender under consideration
- Pt = Price of tender under consideration
- Pmax = Price of highest acceptable tender

4. POINTS AWARDED FOR SPECIFIC GOALS

4.1. In terms of Regulation 4(2); 5(2); 6(2) and 7(2) of the Preferential Procurement Regulations, preference points must be awarded for specific goals stated in the tender. For the purposes of this tender the tenderer will be allocated points based on the goals stated in table 1 below as may be supported by proof/ documentation stated in the conditions of this tender:

4.2. In cases where organs of state intend to use Regulation 3(2) of the Regulations, which states that, if it is unclear whether the 80/20 or 90/10 preference point system applies, an organ of state must, in the tender documents, stipulate in the case of—

- (a) an invitation for tender for income-generating contracts, that either the 80/20 or 90/10 preference point system will apply and that the highest acceptable tender will be used to determine the applicable preference point system; or
- (b) any other invitation for tender, that either the 80/20 or 90/10 preference point system will apply and that the lowest acceptable tender will be used to determine the applicable preference point system, then the organ of state must indicate the points allocated for specific goals for both the 90/10 and 80/20 preference point system. **Table 1: Specific goals for the tender and points claimed are indicated per the table below.**

(Note to organs of state: Where either the 90/10 or 80/20 preference point system is applicable, corresponding points must also be indicated as such.

Note to tenderers: The tenderer must indicate how they claim points for each preference point system.)

The specific goals allocated points in terms of this tender	Number of points allocated (80/20 system) (To be completed by the organ of state)	Number of points claimed (80/20 system) (To be completed by the tenderer)
Locality	4	
Gender	4	
Disability	4	
Youth	4	
Nationality	4	

MBD 6.1

DECLARATION WITH REGARD TO COMPANY/FIRM

4.3. Name of company/firm.....

4.4. Company registration number:

4.5. TYPE OF COMPANY/ FIRM

- Partnership/Joint Venture / Consortium
- One-person business/sole propriety
- Close corporation
- Public Company
- Personal Liability Company
- (Pty) Limited
- Non-Profit Company
- State Owned Company

[TICK APPLICABLE BOX]

4.6. I, the undersigned, who is duly authorised to do so on behalf of the company/firm, certify that the points claimed, based on the specific goals as advised in the tender, qualifies the company/ firm for the preference(s) shown and I acknowledge that:

- i) The information furnished is true and correct; ii) The preference points claimed are in accordance with the General Conditions as indicated in paragraph 1 of this form;
- iii) In the event of a contract being awarded as a result of points claimed as shown in paragraphs 1.4 and 4.2, the contractor may be required to furnish documentary proof to the satisfaction of the organ of state that the claims are correct;
- iv) If the specific goals have been claimed or obtained on a fraudulent basis or any of the conditions of contract have not been fulfilled, the organ of state may, in addition to any other remedy it may have –
 - (a) disqualify the person from the tendering process;
 - (b) recover costs, losses or damages it has incurred or suffered as a result of that person's conduct;
 - (c) cancel the contract and claim any damages which it has suffered as a result of having to make less favourable arrangements due to such cancellation;

- (d) recommend that the tenderer or contractor, its shareholders and directors, or only the shareholders and directors who acted on a fraudulent basis, be restricted from obtaining business from any organ of state for a period not exceeding 10 years, after the *audi alteram partem* (hear the other side) rule has been applied; and
- (e) forward the matter for criminal prosecution, if deemed necessary.

..... SIGNATURE(S) OF TENDERER(S)	
SURNAME AND NAME:
DATE:
ADDRESS:

14. DECLARATION OF BIDDER’S PAST SUPPLY CHAIN MANAGEMENT PRACTICES (MBD 8)

1. This serves as a declaration in ensuring that when goods and services are being procured, all reasonable steps are taken to combat the abuse of the supply chain management system.
2. The bid of any bidder may be rejected if that bidder or any of its directors have:
 - a. abused the municipality’s supply chain management system or committed any improper conduct in relation to such system;
 - b. been convicted for fraud or corruption during the past five years;
 - c. wilfully neglected, reneged on or failed to comply with any government, municipal or other public sector contract during the past five years; or
 - d. been listed in the Register for Tender Defaulters in terms of section 29 of the Prevention and Combating of Corrupt Activities Act (No 12 of 2004).
3. In order to give effect to the above, the following questionnaire must be completed and submitted with the bid.

Item	Question	Yes	No
3.1	Is the bidder or any of its directors listed on the National Treasury’s database as a company or person prohibited from doing business with the public sector? (Companies or persons who are listed on this Database were informed in writing of this restriction by the Accounting Officer/Authority of the institution that imposed the restriction after the <i>audi alteram partem</i> rule was applied). The Database of Restricted Suppliers now resides on the National Treasury’s website (www.treasury.gov.za) and can be accessed by clicking on its link at the bottom of the home page.	Yes <input type="checkbox"/>	No <input type="checkbox"/>
3.1.1	If so, furnish particulars:		

3.2	Is the bidder or any of its directors listed on the Register for Tender Defaulters in terms of section 29 of the Prevention and Combating of Corrupt Activities Act (No 12 of 2004)? The Register for Tender Defaulters can be accessed on the National Treasury's website (www.treasury.gov.za) by clicking on its link at the bottom of the home page.	Yes <input type="checkbox"/>	No <input type="checkbox"/>
3.2.1	If so, furnish particulars:		
3.3	Was the bidder or any of its directors convicted by a court of law (including a court of law outside the Republic of South Africa) for fraud or corruption during the past five years?	Yes <input type="checkbox"/>	No <input type="checkbox"/>
3.3.1	If so, furnish particulars:		
3.4	Does the bidder or any of its directors owe any municipal rates and taxes or municipal charges to the municipality / municipal entity, or to any other municipality / municipal entity, that is in arrears for more than three months?	Yes <input type="checkbox"/>	No <input type="checkbox"/>
3.4.1	If so, furnish particulars:		
3.5	Was any contract between the bidder and the municipality or any other organ of state terminated during the past five years on account of failure to perform on or comply with the contract?	Yes <input type="checkbox"/>	No <input type="checkbox"/>
3.5.1	If so, furnish particulars:		

CERTIFICATION

I, THE UNDERSIGNED (FULL NAME)
CERTIFY THAT THE INFORMATION FURNISHED ON THIS DECLARATION FORM TO BE TRUE AND CORRECT.

I ACCEPT THAT, IN ADDITION TO CANCELLATION OF A CONTRACT, ACTION MAY BE TAKEN AGAINST ME SHOULD THIS DECLARATION PROVE TO BE FALSE.

..... Signature Date
..... Position Name of Bidder

15. CERTIFICATE OF INDEPENDENT BID DETERMINATION (MBD 9)

- 1 Section 4 (1) (b) (iii) of the Competition Act No. 89 of 1998, as amended, prohibits an agreement between, or concerted practice by, firms, or a decision by an association of firms, if it is between parties in a horizontal relationship and if it involves collusive bidding (or bid rigging).* Collusive bidding is a *pe se* prohibition meaning that it cannot be justified under any grounds.
- 2 Municipal Supply Regulation 38 (1) prescribes that a supply chain management policy must provide measures for the combating of abuse of the supply chain management system, and must enable the accounting officer, among others, to:
 - a. take all reasonable steps to prevent such abuse;
 - b. reject the bid of any bidder if that bidder or any of its directors has abused the supply chain management system of the municipality or municipal entity or has committed any improper conduct in relation to such system; and
 - c. cancel a contract awarded to a person if the person committed any corrupt or fraudulent act during the bidding process or the execution of the contract.
- 3 This **MBD** serves as a certificate of declaration that would be used by institutions to ensure that, when bids are considered, reasonable steps are taken to prevent any form of bid-rigging.
- 4 In order to give effect to the above, the attached Certificate of Bid Determination (**MBD 9**) must be completed and submitted with the bid:

* Bid rigging (or collusive bidding) occurs when businesses, that would otherwise be expected to compete, secretly conspire to raise prices or lower the quality of goods and / or services for purchasers who wish to acquire goods and / or services through a bidding process. Bid rigging is, therefore, an agreement between competitors not to compete.

CERTIFICATE OF BID DETERMINATION

I, the undersigned, in submitting the accompanying bid:

BID NO: RMLM SCM:2025/2026: COMM-05B APPOINTMENT OF A GENERAL BUILDING CONTRACTOR CIBB GRADING 3GB OR HIGHER FOR SUPPLY, DELIVERY AND INSTALLATION OF CONCRETE PALISADE FENCE AND A STEEL GATE AT IKAGELENG CEMETERY.

in response to the invitation for the bid made by:

Ramotshere Moiloa Local Municipality

do hereby make the following statements that I certify to be true and complete in every respect:

I certify, on behalf of: _____ that: (Name
of Bidder)

1. I have read and I understand the contents of this Certificate;
2. I understand that the accompanying bid will be disqualified if this Certificate is found not to be true and complete in every respect;
3. I am authorized by the bidder to sign this Certificate, and to submit the accompanying bid, on behalf of the bidder;
4. Each person whose signature appears on the accompanying bid has been authorized by the bidder to determine the terms of, and to sign, the bid, on behalf of the bidder;
5. For the purposes of this Certificate and the accompanying bid, I understand that the word "competitor" shall include any individual or organization, other than the bidder, whether or not affiliated with the bidder, who:
 - (a) has been requested to submit a bid in response to this bid invitation;
 - (b) could potentially submit a bid in response to this bid invitation, based on their qualifications, abilities or experience; and
 - (c) provides the same goods and services as the bidder and/or is in the same line of business as the bidder
6. The bidder has arrived at the accompanying bid independently from, and without consultation, communication, agreement or arrangement with any competitor. However communication between partners in a joint venture or consortium* will not be construed as collusive bidding.
7. In particular, without limiting the generality of paragraphs 6 above, there has been no consultation, communication, agreement or arrangement with any competitor regarding:
 - (a) prices;
 - (b) geographical area where product or service will be rendered (market allocation)
 - (c) methods, factors or formulas used to calculate prices;
 - (d) the intention or decision to submit or not to submit, a bid;
 - (e) the submission of a bid which does not meet the specifications and conditions of the bid; or (f) bidding with the intention not to win the bid.

- 8. In addition, there have been no consultations, communications, agreements or arrangements with any competitor regarding the quality, quantity, specifications and conditions or delivery particulars of the products or services to which this bid invitation relates.
- 9. The terms of the accompanying bid have not been, and will not be, disclosed by the bidder, directly or indirectly, to any competitor, prior to the date and time of the official bid opening or of the awarding of the contract.
- 10. I am aware that, in addition and without prejudice to any other remedy provided to combat any restrictive practices related to bids and contracts, bids that are suspicious will be reported to the Competition Commission for investigation and possible imposition of administrative penalties in terms of section 59 of the Competition Act No. 89 of 1998 and or may be reported to the National Prosecuting Authority (NPA) for criminal investigation and or may be restricted from conducting business with the public sector for a period not exceeding ten (10) years in terms of the Prevention and Combating of Corrupt Activities Act No. 12 of 2004 or any other applicable legislation.

..... Signature Date
..... Position Name of Bidder

* Joint venture or Consortium means an association of persons for the purpose of combining their expertise, property, capital, efforts, skill and knowledge in an activity for the execution of a contract.

16. Annexure A: Government Procurement: General Conditions of Contract (July 2010)

**THE NATIONAL TREASURY
Republic of South Africa**

**GOVERNMENT PROCUREMENT:
GENERAL CONDITIONS OF CONTRACT
July 2010**

TABLE OF CLAUSES

- 1. Definitions
- 2. Application
- 3. General

4. Standards
5. Use of contract documents and information inspection
6. Patent Rights
7. Performance security
8. Inspections, tests and analyses
9. Packing
10. Delivery and documents
11. Insurance
12. Transportation
13. Incidental Services
14. Spare parts
15. Warranty
16. Payment
17. Prices
18. Variation orders
19. Assignment
20. Subcontracts
21. Delays in the supplier's performance
22. Penalties
23. Termination for default
24. Anti-dumping and countervailing duties and rights
25. Force Majeure
26. Termination for insolvency
27. Settlement of Disputes
28. Limitation of Liability
29. Governing language
30. Applicable law
31. Notices
32. Taxes and duties
33. Transfer of contracts
34. Amendments of contracts
35. Prohibition of restrictive practices

General Conditions of Contract

1. Definitions

1. The following terms shall be interpreted as indicated:
 - 1.1 "Closing time" means the date and hour specified in the bidding documents for the receipt of bids.
 - 1.2 "Contract" means the written agreement entered into between the purchaser and the supplier, as recorded in the contract form signed by the parties, including all attachments and appendices thereto and all documents incorporated by reference therein.
 - 1.3 "Contract price" means the price payable to the supplier under the contract for the full and proper performance of his contractual obligations.
 - 1.4 "Corrupt practice" means the offering, giving, receiving, or soliciting of anything of value to influence the action of a public official in the procurement process or in contract execution.
 - 1.5 "Countervailing duties" are imposed in cases where an enterprise abroad is subsidized by its government and encouraged to market its products internationally.

- 1.6 "Country of origin" means the place where the goods were mined, grown or produced or from which the services are supplied. Goods are produced when, through manufacturing, processing or substantial and major assembly of components, a commercially recognized new product results that is substantially different in basic characteristics or in purpose or utility from its components.
- 1.7 "Day" means calendar day.
- 1.8 "Delivery" means delivery in compliance of the conditions of the contract or order.
- 1.9 "Delivery ex stock" means immediate delivery directly from stock actually on hand.
- 1.10 "Delivery into consignees store or to his site" means delivered and unloaded in the specified store or depot or on the specified site in compliance with the conditions of the contract or order, the supplier bearing all risks and charges involved until the goods are so delivered and a valid receipt is obtained.
- 1.11 "Dumping" occurs when a private enterprise abroad market its goods on own initiative in the RSA at lower prices than that of the country of origin and which have the potential to harm the local industries in the RSA.
- 1.12 "Force majeure" means an event beyond the control of the supplier and not involving the supplier's fault or negligence and not foreseeable. Such events may include, but is not restricted to, acts of the purchaser in its sovereign capacity, wars or revolutions, fires, floods, epidemics, quarantine restrictions and freight embargoes.
- 1.13 "Fraudulent practice" means a misrepresentation of facts in order to influence a procurement process or the execution of a contract to the detriment of any bidder, and includes collusive practice among bidders (prior to or after bid submission) designed to establish bid prices at artificial non-competitive levels and to deprive the bidder of the benefits of free and open competition.
- 1.14 "GCC" means the General Conditions of Contract.
- 1.15 "Goods" means all of the equipment, machinery, and/or other materials that the supplier is required to supply to the purchaser under the contract.
- 1.16 "Imported content" means that portion of the bidding price represented by the cost of components, parts or materials which have been or are still to be imported (whether by the supplier or his subcontractors) and which costs are inclusive of the costs abroad, plus freight and other direct importation costs such as landing costs, dock dues, import duty, sales duty or other similar tax or duty at the South African place of entry as well

28

as transportation and handling charges to the factory in the Republic where the goods covered by the bid will be manufactured.

- 1.17 "Local content" means that portion of the bidding price, which is not included in the imported content provided that local manufacture does take place.
- 1.18 "Manufacture" means the production of products in a factory using labour, materials, components and machinery and includes other related value-adding activities.
- 1.19 "Order" means an official written order issued for the supply of goods or works or the rendering of a service.
- 1.20 "Project site," where applicable, means the place indicated in bidding documents.

1.21 "Purchaser" means the organization purchasing the goods.

1.22 "Republic" means the Republic of South Africa.

1.23 "SCC" means the Special Conditions of Contract.

1.24 "Services" means those functional services ancillary to the supply of the goods, such as transportation and any other incidental services, such as installation, commissioning, provision of technical assistance, training, catering, gardening, security, maintenance and other such obligations of the supplier covered under the contract.

1.25 "Supplier" means the successful bidder who is awarded the contract to maintain and administer the required and specified service(s) to the State.

1.26 "Tort" means in breach of contract.

1.27 "Turnkey" means a procurement process where one service provider assumes total responsibility for all aspects of the project and delivers the full end product / service required by the contract.

1.28 "Written" or "in writing" means hand-written in ink or any form of electronic or mechanical writing.

2. Application

2.1 These general conditions are applicable to all bids, contracts and orders including bids for functional and professional services (excluding professional services related to the building and construction industry), sales, hiring, letting and the granting or acquiring of rights, but excluding immovable property, unless otherwise indicated in the bidding documents.

2.2 Where applicable, special conditions of contract are also laid down to cover specific goods, services or works.

2.3 Where such special conditions of contract are in conflict with these general conditions, the special conditions shall apply.

3. General

3.1 Unless otherwise indicated in the bidding documents, the purchaser shall not be liable for any expense incurred in the preparation and submission of a bid. Where applicable a non-refundable fee for documents may be charged.

3.2 Invitations to bid are usually published in locally distributed news media and on the municipality/municipal entity website.

4. Standards

4.1 The goods supplied shall conform to the standards mentioned in the bidding documents and specifications.

5. Use of contract documents and information inspection

5.1 The supplier shall not, without the purchaser's prior written consent, disclose the contract, or any provision thereof, or any specification, plan, drawing, pattern, sample, or information furnished by or on behalf of the purchaser in connection therewith, to any person other than a person employed by the supplier in the performance of the contract. Disclosure to any such employed person shall be made in confidence and shall extend only so far as may be necessary for purposes of such performance.

5.2 The supplier shall not, without the purchaser's prior written consent, make use of any document or information mentioned in GCC clause 5.1 except for purposes of performing the contract.

5.3 Any document, other than the contract itself mentioned in GCC clause 5.1 shall remain the property of the purchaser and shall be returned (all copies) to the purchaser on completion of the supplier's performance under the contract if so required by the purchaser.

5.4 The supplier shall permit the purchaser to inspect the supplier's records relating to the performance of the supplier and to have them audited by auditors appointed by the purchaser, if so required by the purchaser.

6. Patent Rights

6.1 The supplier shall indemnify the purchaser against all third-party claims of infringement of patent, trademark, or industrial design rights arising from use of the goods or any part thereof by the purchaser.

6.2 When a supplier developed documentation / projects for the municipality / municipal entity, the intellectual, copy and patent rights or ownership of such documents or projects will vest in the municipality / municipal entity.

7. Performance security

7.1 Within thirty (30) days of receipt of the notification of contract award, the successful bidder shall furnish to the purchaser the performance security of the amount specified in SCC.

7.2 The proceeds of the performance security shall be payable to the purchaser as compensation for any loss resulting from the supplier's failure to complete his obligations under the contract.

7.3 The performance security shall be denominated in the currency of the contract, or in a freely convertible currency acceptable to the purchaser and shall be in one of the following forms:

- (a) a bank guarantee or an irrevocable letter of credit issued by a reputable bank located in the purchaser's country or abroad, acceptable to the purchaser, in the form provided in the bidding documents or another form acceptable to the purchaser; or (b) a cashier's or certified cheque.

7.4 The performance security will be discharged by the purchaser and returned to the supplier not later than thirty (30) days following the date of completion of the supplier's performance obligations under the contract, including any warranty obligations, unless otherwise specified.

8. Inspections, tests and analyses

8.1 All pre-bidding testing will be for the account of the bidder.

8.2 If it is a bid condition that goods to be produced or services to be rendered should at any stage be subject to inspections, tests and analyses, the bidder or contractor's premises shall be open, at all reasonable hours, for inspection by a representative of the purchaser or organization acting on behalf of the purchaser.

8.3 If there are no inspection requirements indicated in the bidding documents and no mention is made in the contract, but during the contract period it is decided that inspections shall be carried out, the purchaser shall

30

itself make the necessary arrangements, including payment arrangements with the testing authority concerned.

8.4 If the inspections, tests and analyses referred to in clauses 8.2 and 8.3 show the goods to be in accordance with the contract requirements, the cost of the inspections, tests and analyses shall be defrayed by the purchaser.

8.5 Where the goods or services referred to in clauses 8.2 and 8.3 do not comply with the contract requirements, irrespective of whether such goods or services are accepted or not, the cost in connection with these inspections, tests or analyses shall be defrayed by the supplier.

8.6 Goods and services which are referred to in clauses 8.2 and 8.3 and which do not comply with the contract requirements may be rejected.

8.7 Any contract goods may on or after delivery be inspected, tested or analysed and may be rejected if found not to comply with the requirements of the contract. Such rejected goods shall be held at the cost and risk of the supplier who shall, when called upon, remove them immediately at his own cost and forthwith substitute them with goods, which do comply with the requirements of the contract. Failing such removal the rejected goods shall be returned at the suppliers cost and risk. Should the supplier fail to provide the substitute goods forthwith, the purchaser may, without giving the supplier further opportunity to substitute the rejected goods, purchase such goods as may be necessary at the expense of the supplier.

8.8 The provisions of clauses 8.4 to 8.7 shall not prejudice the right of the purchaser to cancel the contract on account of a breach of the conditions thereof, or to act in terms of Clause 22 of GCC.

9. Packing

9.1 The supplier shall provide such packing of the goods as is required to prevent their damage or deterioration during transit to their final destination, as indicated in the contract. The packing shall be sufficient to withstand, without limitation, rough handling during transit and exposure to extreme temperatures, salt and precipitation during transit, and open storage. Packing, case size weights shall take into consideration, where appropriate, the remoteness of the goods' final destination and the absence of heavy handling facilities at all points in transit.

9.2 The packing, marking, and documentation within and outside the packages shall comply strictly with such special requirements as shall be expressly provided for in the contract, including additional requirements, if any, and in any subsequent instructions ordered by the purchaser.

10. Delivery and documents

10.1 Delivery of the goods and arrangements for shipping and clearance obligations shall be made by the supplier in accordance with the terms specified in the contract.

11. Insurance

11.1 The goods supplied under the contract shall be fully insured in a freely convertible currency against loss or damage incidental to manufacture or acquisition, transportation, storage and delivery in the manner specified.

12. Transportation

12.1 Should a price other than an all-inclusive delivered price be required, this shall be specified.

13. Incidental Services

13.1 The supplier may be required to provide any or all of the following services, including additional services, if any:

- (a) performance or supervision of on-site assembly and/or commissioning of the supplied goods;
- (b) furnishing of tools required for assembly and/or maintenance of the supplied goods;

- (c) furnishing of a detailed operations and maintenance manual for each appropriate unit of the supplied goods;
- (d) performance or supervision or maintenance and/or repair of the supplied goods, for a period of time agreed by the parties, provided that this service shall not relieve the supplier of any warranty obligations under this contract; and
- (e) training of the purchaser's personnel, at the supplier's plant and/or on-site, in assembly, start-up, operation, maintenance, and/or repair of the supplied goods.

13.2 Prices charged by the supplier for incidental services, if not included in the contract price for the goods, shall be agreed upon in advance by the parties and shall not exceed the prevailing rates charged to other parties by the supplier for similar services.

14. Spare parts

14.1 As specified, the supplier may be required to provide any or all of the following materials, notifications, and information pertaining to spare parts manufactured or distributed by the supplier:

- (a) such spare parts as the purchaser may elect to purchase from the supplier, provided that this election shall not relieve the supplier of any warranty obligations under the contract; and; (b) in the event of termination of production of the spare parts:
 - (i) advance notification to the purchaser of the pending termination, in sufficient time to permit the purchaser to procure needed requirements; and
 - (ii) following such termination, furnishing at no cost to the purchaser, the blueprints, drawings, and specifications of the spare parts, if requested.

15. Warranty

15.1 The supplier warrants that the goods supplied under the contract are new, unused, of the most recent or current models, and that they incorporate all recent improvements in design and materials unless provided otherwise in the contract. The supplier further warrants that all goods supplied under this contract shall have no defect, arising from design, materials, or workmanship (except when the design and/or material is required by the purchaser's specifications) or from any act or omission of the supplier, that may develop under normal use of the supplied goods in the conditions prevailing in the country of final destination.

15.2 This warranty shall remain valid for twelve (12) months after the goods, or any portion thereof as the case may be, have been delivered to and accepted at the final destination indicated in the contract, or for eighteen (18) months after the date of shipment from the port or place of loading in the source country, whichever period concludes earlier, unless specified otherwise.

15.3 The purchaser shall promptly notify the supplier in writing of any claims arising under this warranty.

15.4 Upon receipt of such notice, the supplier shall, within the period specified and with all reasonable speed, repair or replace the defective goods or parts thereof, without costs to the purchaser.

15.5 If the supplier, having been notified, fails to remedy the defect(s) within the period specified, the purchaser may proceed to take such remedial action as may be necessary, at the supplier's risk and expense and without prejudice to any other rights which the purchaser may have against the supplier under the contract.

16. Payment

16.1 The method and conditions of payment to be made to the supplier under this contract shall be specified.

16.2 The supplier shall furnish the purchaser with an invoice accompanied by a copy of the delivery note and upon fulfilment of other obligations stipulated in the contract.

16.3 Payments shall be made promptly by the purchaser, but in no case later than thirty (30) days after submission of an invoice or claim by the supplier.

16.4 Payment will be made in Rand unless otherwise stipulated.

17. Prices

17.1 Prices charged by the supplier for goods delivered and services performed under the contract shall not vary from the prices quoted by the supplier in his bid, with the exception of any price adjustments authorized or in the purchaser's request for bid validity extension, as the case may be.

18. Variation orders

18.1 In cases where the estimated value of the envisaged changes in purchase does not vary more than 15% of the total value of the original contract, the contractor may be instructed to deliver the goods or render the services as such. In cases of measurable quantities, the contractor may be approached to reduce the unit price, and such offers may be accepted provided that there is no escalation in price.

19. Assignment

19.1 The supplier shall not assign, in whole or in part, its obligations to perform under the contract, except with the purchaser's prior written consent.

20. Subcontracts

20.1 The supplier shall notify the purchaser in writing of all subcontracts awarded under this contract if not already specified in the bid. Such notification, in the original bid or later, shall not relieve the supplier from any liability or obligation under the contract.

21. Delays in the supplier's performance

21.1 Delivery of the goods and performance of services shall be made by the supplier in accordance with the time schedule prescribed by the purchaser in the contract.

21.2 If at any time during performance of the contract, the supplier or its subcontractor(s) should encounter conditions impeding timely delivery of the goods and performance of services, the supplier shall promptly notify the purchaser in writing of the fact of the delay, its likely duration and its cause(s). As soon as practicable after receipt of the supplier's notice, the purchaser shall evaluate the situation and may at his discretion extend the supplier's time for performance, with or without the imposition of penalties, in which case the extension shall be ratified by the parties by amendment of contract.

21.3 The right is reserved to procure outside of the contract small quantities or to have minor essential services executed if an emergency arises, the supplier's point of supply is not situated at or near the place where the goods are required, or the supplier's services are not readily available.

21.4 Except as provided under GCC Clause 25, a delay by the supplier in the performance of its delivery obligations shall render the supplier liable to the imposition of penalties, pursuant to GCC Clause 22, unless an extension of time is agreed upon pursuant to GCC Clause 22.2 without the application of penalties.

21.5 Upon any delay beyond the delivery period in the case of a goods contract, the purchaser shall, without cancelling the contract, be entitled to purchase goods of a similar quality and up to the same quantity in substitution of the goods not supplied in conformity with the contract and to return any goods delivered later at

the supplier's expense and risk, or to cancel the contract and buy such goods as may be required to complete the contract and without prejudice to his other rights, be entitled to claim damages from the supplier.

22. Penalties

22.1 Subject to GCC Clause 25, if the supplier fails to deliver any or all of the goods or to perform the services within the period(s) specified in the contract, the purchaser shall, without prejudice to its other remedies under the contract, deduct from the contract price, as a penalty, a sum calculated on the delivered price of the delayed goods or unperformed services using the current prime interest rate calculated for each day of the delay until actual delivery or performance. The purchaser may also consider termination of the contract pursuant to GCC Clause 23.

23. Termination for default

23.1 The purchaser, without prejudice to any other remedy for breach of contract, by written notice of default sent to the supplier, may terminate this contract in whole or in part:

- (a) if the supplier fails to deliver any or all of the goods within the period(s) specified in the contract, or within any extension thereof granted by the purchaser pursuant to GCC Clause 21.2;
- (b) if the supplier fails to perform any other obligation(s) under the contract; or
- (c) if the supplier, in the judgement of the purchaser, has engaged in corrupt or fraudulent practices in competing for or in executing the contract.

23.2 In the event the purchaser terminates the contract in whole or in part, the purchaser may procure, upon such terms and in such manner, as it deems appropriate, goods, works or services similar to those undelivered, and the supplier shall be liable to the purchaser for any excess costs for such similar goods, works or services. However, the supplier shall continue performance of the contract to the extent not terminated.

23.3 Where the purchaser terminates the contract in whole or in part, the purchaser may decide to impose a restriction penalty on the supplier by prohibiting such supplier from doing business with the public sector for a period not exceeding 10 years.

23.4 If a purchaser intends imposing a restriction on a supplier or any person associated with the supplier, the supplier will be allowed a time period of not more than fourteen (14) days to provide reasons why the envisaged restriction should not be imposed. Should the supplier fail to respond within the stipulated fourteen (14) days the purchaser may regard the supplier as having no objection and proceed with the restriction.

23.5 . Any restriction imposed on any person by the purchaser will, at the discretion of the purchaser, also be applicable to any other enterprise or any partner, manager, director or other person who wholly or partly exercises or exercised or may exercise control over the enterprise of the first-mentioned person, and with which enterprise or person the first-mentioned person, is or was in the opinion of the purchaser actively associated.

23.6 If a restriction is imposed, the purchaser must, within five (5) working days of such imposition, furnish the National Treasury, with the following information:

- (i) the name and address of the supplier and / or person restricted by the purchaser;
- (ii) the date of commencement of the restriction
- (iii) the period of restriction; and
- (iv) the reasons for the restriction.

These details will be loaded in the National Treasury's central database of suppliers or persons prohibited from doing business with the public sector.

23.7 . If a court of law convicts a person of an offence as contemplated in sections 12 or 13 of the Prevention and Combating of Corrupt Activities Act, No. 12 of 2004, the court may also rule that such person's name be endorsed on the Register for Tender Defaulters. When a person's name has been endorsed on the Register,

the person will be prohibited from doing business with the public sector for a period not less than five years and not more than 10 years. The National Treasury is empowered to determine the period of restriction and each case will be dealt with on its own merits. According to section 32 of the Act the Register must be open to the public. The Register can be perused on the National Treasury website

24. Antidumping and countervailing duties and rights

24.1 When, after the date of bid, provisional payments are required, or anti-dumping or countervailing duties are imposed, or the amount of a provisional payment or anti-dumping or countervailing right is increased in respect of any dumped or subsidized import, the State is not liable for any amount so required or imposed, or for the amount of any such increase. When, after the said date, such a provisional payment is no longer required or any such anti-dumping or countervailing right is abolished, or where the amount of such provisional payment or any such right is reduced, any such favourable difference shall on demand be paid forthwith by the supplier to the purchaser or the purchaser may deduct such amounts from moneys (if any) which may otherwise be due to the supplier in regard to goods or services which he delivered or rendered, or is to deliver or render in terms of the contract or any other contract or any other amount which may be due to him.

25. Force Majeure

25.1 Notwithstanding the provisions of GCC Clauses 22 and 23, the supplier shall not be liable for forfeiture of its performance security, damages, or termination for default if and to the extent that his delay in performance or other failure to perform his obligations under the contract is the result of an event of force majeure.

25.2 If a force majeure situation arises, the supplier shall promptly notify the purchaser in writing of such condition and the cause thereof. Unless otherwise directed by the purchaser in writing, the supplier shall continue to perform its obligations under the contract as far as is reasonably practical, and shall seek all reasonable alternative means for performance not prevented by the force majeure event.

26. Termination for insolvency

26.1 The purchaser may at any time terminate the contract by giving written notice to the supplier if the supplier becomes bankrupt or otherwise insolvent. In this event, termination will be without compensation to the supplier, provided that such termination will not prejudice or affect any right of action or remedy, which has accrued or will accrue thereafter to the purchaser.

27. Settlement of Disputes

27.1 If any dispute or difference of any kind whatsoever arises between the purchaser and the supplier in connection with or arising out of the contract, the parties shall make every effort to resolve amicably such dispute or difference by mutual consultation.

27.2 If, after thirty (30) days, the parties have failed to resolve their dispute or difference by such mutual consultation, then either the purchaser or the supplier may give notice to the other party of his intention to commence with mediation. No mediation in respect of this matter may be commenced unless such notice is given to the other party.

27.3 Should it not be possible to settle a dispute by means of mediation, it may be settled in a South African court of law.

27.4 Notwithstanding any reference to mediation and/or court proceedings herein,

- (a) the parties shall continue to perform their respective obligations under the contract unless they otherwise agree; and
- (b) the purchaser shall pay the supplier any monies due the supplier for goods delivered and / or services rendered according to the prescripts of the contract.

28. Limitation of Liability

28.1 Except in cases of criminal negligence or wilful misconduct, and in the case of infringement pursuant to Clause 6;

- (a) the supplier shall not be liable to the purchaser, whether in contract, tort, or otherwise, for any indirect or consequential loss or damage, loss of use, loss of production, or loss of profits or interest costs, provided that this exclusion shall not apply to any obligation of the supplier to pay penalties and/or damages to the purchaser; and
- (b) the aggregate liability of the supplier to the purchaser, whether under the contract, in tort or otherwise, shall not exceed the total contract price, provided that this limitation shall not apply to the cost of repairing or replacing defective equipment.

29. Governing language

29.1 The contract shall be written in English. All correspondence and other documents pertaining to the contract that is exchanged by the parties shall also be written in English.

30. Applicable law

30.1 The contract shall be interpreted in accordance with South African laws, unless otherwise specified.

31. Notices

31.1 Every written acceptance of a bid shall be posted to the supplier concerned by registered or certified mail and any other notice to him shall be posted by ordinary mail to the address furnished in his bid or to the address notified later by him in writing and such posting shall be deemed to be proper service of such notice.

31.2 The time mentioned in the contract documents for performing any act after such aforesaid notice has been given, shall be reckoned from the date of posting of such notice.

32. Taxes and duties

32.1 A foreign supplier shall be entirely responsible for all taxes, stamp duties, license fees, and other such levies imposed outside the purchaser's country.

32.2 A local supplier shall be entirely responsible for all taxes, duties, license fees, etc., incurred until delivery of the contracted goods to the purchaser.

32.3 No contract shall be concluded with any bidder whose tax matters are not in order. Prior to the award of a bid SARS must have certified that the tax matters of the preferred bidder are in order.

32.4 No contract shall be concluded with any bidder whose municipal rates and taxes and municipal services charges are in arrears.

33. Transfer of contracts

33.1 The contractor shall not abandon, transfer, cede assign or sublet a contract or part thereof without the written permission of the purchaser

34. Amendment of contracts

34.1 No agreement to amend or vary a contract or order or the conditions, stipulations or provisions thereof shall be valid and of any force unless such agreement to amend or vary is entered into in writing and signed by the contracting parties. Any waiver of the requirement that the agreement to amend or vary shall be in writing, shall also be in writing.

35. Prohibition of restrictive practices

35.1 In terms of section 4 (1) (b) (iii) of the Competition Act No. 89 of 1998, as amended, an agreement between, or concerted practice by, firms, or a decision by an association of firms, is prohibited if it is between parties in a horizontal relationship and if a bidder(s) is / are or a contractor(s) was / were involved in collusive bidding.

35.2 If a bidder(s) or contractor(s) based on reasonable grounds or evidence obtained by the purchaser has / have engaged in the restrictive practice referred to above, the purchaser may refer the matter to the

Competition Commission for investigation and possible imposition of administrative penalties as contemplated in section 59 of the Competition Act No 89 Of 1998.

35.3 If a bidder(s) or contractor(s) has / have been found guilty by the Competition Commission of the restrictive practice referred to above, the purchaser may, in addition and without prejudice to any other remedy provided for, invalidate the bid(s) for such item(s) offered, and / or terminate the contract in whole or part, and / or restrict the bidder(s) or contractor(s) from conducting business with the public sector for a period not exceeding ten (10) years and / or claim damages from the bidder(s) or contractor(s) concerned.

FENCING OF IKAGELENG CEMETERY SITE - WARD 16



Situated In

RAMOTSHERE MOILOA LOCAL MUNICIPALITY

C2.1: PRICING INSTRUCTIONS

1. GENERAL

The pricing instructions describe the criteria and assumptions which will be assumed in the Contract that the Bidder has taken into account when developing his prices. The Bills of Quantities record the Contractor's rates for providing supplies, services, engineering and construction works in accordance with the Scope of Work.

The terms of payment and the provisions for price adjustment, if applicable, are established in the Contract Data. These items are not described in the Pricing Data.

The Bidder's obligations in pricing the Bid offer and the Employer's undertakings in the checking and correction of arithmetical errors are dealt with in the Standard Conditions of Bid contained in Annexure F of SANS 294, as amended in and read in conjunction with the Bid Data.

2. **DOCUMENTS MUTUALLY EXPLANATORY**

The documents forming the Contract are to be taken as mutually explanatory of one another. The Bill of Quantities forms an integral part of the Contract Documents and shall be read in conjunction with the Bid Data, Contract Data, Scope of Work, Site Information General and Special Conditions of Contract, the Specifications and the Drawings.

3. **DEFINITIONS**

For the purpose of this Bill of Quantities, the following words shall have the meanings hereby assigned to them:

- Unit : The unit of measurement for each item of work as defined in the COLTO Standard Specification for Road and Bridge Works for State Authorities (1998 edition).
- Quantity : The number of units of work for each item
- Rate : The payment per unit of measurement at which the Bidder Bids to do the work.
- 38
- Amount : The product of the quantity and the rate Bided for an item
- Sum : An amount Bided for an item, the extent of which is described in the Schedule of Quantities, the specifications or elsewhere but the quantity of work of which is not measured in any units.
- Prime Cost (or PC item) : A sum fixed by the Engineer and entered in the Schedule of Quantities as the net sum provided to cover the cost of specific goods or materials to be supplied under the contract, or the net sum to be paid by the Contractor to merchants or others for such articles or materials.¹
- Provisional Sum : A sum of money fixed by the Engineer and entered in the Schedule of Quantities to provide for work not defined at the Bid stage and includes any allowance specifically made for unforeseen contingencies.¹
- Extra Over (or EO) : Qualifies an operation (or combination of operations) which is common in a varying degree to a number of other operations and which is scheduled once as "extra over" those other operations in order to avoid a multiplicity of items each reflecting the degree to which the common operations apply. The term "extra

over” invariably denoted double measurement, no deduction being made from one on account of the other.¹

4. DESCRIPTIONS

Descriptions in the Bill of Quantities are abbreviated and comply generally with those in the Standardised Specifications. Clause 8 of each Standardised Specification, read together with the relevant clauses of the Scope of Work, set out what ancillary or associated activities are included in the rates for the operations specified. Should any requirements of the measurement and payment clause of the applicable Standardised Specification, or the Scope of Work, conflict with the terms of the Bill, the requirements of the Standardised Specification or Scope of Work, as applicable, shall prevail.

5. REFERENCES

The general conditions of contract, the special conditions of contract (if any), the specifications (including the project specification) and the drawings are to be read in conjunction with the schedule of quantities.

Descriptions in the schedule of quantities are abbreviated and the schedule has been drawn up generally in accordance with the COLTO Standard Specification for Road and Bridge Works for State Authorities (1998 edition) as amended in the Scope of Works. Should any requirement of the measurement and payment clause of the applicable standardised specification², or the project specification², or the particular specification(s)² conflict with the terms of the schedule or, when relevant, COLTO¹, the requirement of the standardised, project or particular specification, as applicable, shall prevail.

Unless otherwise stated, items are measured net in accordance with the drawings, and no allowance has been made for waste.

The prices and rates to be inserted in the schedule of quantities are to be the full inclusive prices to the Employer for the work described under the several items, value added tax excluded. Such prices shall cover all costs and expenses that may be required in and for the construction of the work described, and shall cover the cost of all general risks, liabilities and obligations set forth or implied in the documents on which the quotation is based.

A price or rate is to be entered against each item in the schedule of quantities, whether the quantities are stated or not. An item against which no price is entered will be considered to be covered by the other prices or rates in the schedule

6. UNITS OF MEASUREMENT

The units of measurement indicated in the Bill of Quantities are metric units.

The following abbreviations are used in the Bill of Quantities:

%	=	per cent	h
	=	hour	
ha	=	hectare	kg = kilogram
	=	kl	= kilolitre
km	=	kilometre	
km-pass	=	kilometre-pass	
kW	=	kilowatt	l = litre
	=	metre	m =
mm	=	millimetre	
MN	=	mega	
newton			
MN-m	=	mega newton-metre	
MPa	=	mega Pascal	
kPa	=	kilopascal	m ²
	=	square metre	m ³
	=	cubic metre	
m ³ -km	=	cubic metre-kilometre	m ² -pass
	=	square metre-pass	
no	=	number	
PC sum	=	Prime Cost sum	
Prov Sum	=	Provisional Sum	
sum	=	lump sum	
t	=	ton (1 000 kg)	
R/only	=	Rate only	
W/day	=	Work day	

7. NET MEASUREMENTS

Unless otherwise stated, items are measured net in accordance with the drawings, and no allowance is made for off-cuts and waste.

8. QUANTITIES

The quantities set out in these Bills of Quantities are approximate and do not necessarily represent the actual amount of work to be done. The quantities of work accepted and certified for payment will be used for determining payments due and not the quantities given in the Bills of Quantities.

The Contract Amount to be determined in accordance with the conditions of contract identified in the Contract Data shall be computed from the actual quantities of authorized work done, value at rates determined in terms of the Contract Data, against the respective items in the Bill of Quantities.

The item numbers appearing in the Bills of Quantities refer to the corresponding item numbers in the COLTO Standard Specification for Road and Bridge Works for State Road Authorities (1998 edition).

9. CURRENCY

All rates and sums of money quoted in the Bill of Quantities shall be in Rand and whole cents. Fractions of a cent shall be discounted.

10. VALUE ADDED TAX

Value Added Tax shall be excluded from the rates and sums contracted for the various items of work included in the Bill of Quantities. VAT will be added as a single entry to the summary.

11. RATES AND PRICES

11.1 General

- a) The Contractor must price each item in the Bill of Quantities in BLACK INK. Reproduced computer printouts of the Bills of Quantities will not be acceptable.
- b) The rates and prices to be inserted in the Bill of Quantities shall cover all the services and incidentals for the work described under the several items. Such prices and rates shall cover all costs and expenses that may be required in and for the execution of the work described, and shall cover the cost of all general risks, liabilities and obligations set forth or implied in the documents on which the Bid is based, as well as overhead charges and profit. Reasonable prices shall be inserted as these will be used as a basis for assessment of payment for additional work that may have to be carried out.
- c) Where the Contractor is required to furnish detailed drawings and designs or other information in terms of the Contract Data, all costs thereof shall be deemed to have been provided for and included in the unit rates and sum amounts contracted for the items scheduled in the Bill of Quantities. Separate additional payments will not be made.
- d) A price or rate is to be entered against each item in the Bill of Quantities, whether the quantities are stated or not. An item against which no price is entered will be considered to be covered by the other prices or rates in the Bill. The Contractor will not be paid for items against which no rate or lump sum has been entered in the Bill of Quantities.
- e) Should the Contractor group a number of items and contract one lump sum for such group of items, this single lump sum shall apply to that group of items and not to each individual item.
- f) Should the Contractor indicate against any item that compensation for such item is included in another item; the rate for the item included in another item shall be deemed nil.

- g) A submission may be regarded as non-responsive if any rates or lump sums in the Bill of Quantities are, in the opinion of the Employer, unreasonable or out of proportion.

11.2 “Rate only” items

The Contractor shall fill in a rate (in the rate column) against all items where the words "rate only" appear in the Amount column, which rate will constitute payment for work which may be done in terms of this item. Such "rate-only" items are used where it is estimated that little or no work will be required under the item or where the item is to be considered as an alternative to another item for which a quantity is given.

11.3 Arithmetic

Excepting where Sum Amounts are required or where Provisional Sums have been indicated, the Contractor shall enter an applicable rate in the Rate Column of the Bill of Quantities for each scheduled item. He shall also enter an appropriate sum in the Amount column for each scheduled item, by determining in the applicable line item the product of the Quantity and the Unit Rate.

If there is an error in the line item resulting from the product of the unit rate and the quantity, the rate shall be binding and the error of extension as entered in the Bid offer will be corrected by the Employer in determining the Contract Price.

Where there is an error in addition, either as a result of other corrections required by this checking process or in the Bidder's addition of prices, such error will be corrected by the Employer in determining the Contract Price.

12. VARIATION IN TEXT

No alteration, erasure or addition is to be made in the text of the Bill of Quantities. Should any alteration, erasure or addition be made, it will not be recognized; the original wording of the Bill of Quantities will be adhered to.

13 LABOUR INTENSIVE ACTIVITIES

Those parts of the contract to be constructed using labour-intensive methods have been marked in the bill of quantities with the letters LI in a separate column or as a prefix or suffix against every item so designated. The works, or parts of the works so designated are to be constructed using labour-intensive methods only. The use of plant to provide such works, other than plant specifically provided for in the scope of works, is a deviation from the contract. The items marked with the letters 'LI' are not necessarily an exhaustive list of all the activities, which must be done by hand, and this clause does not over-ride any of the requirements in the generic labour intensive specification in the Scope of Works.

14 IDENTIFICATION OF LABOUR INTENSIVE ON CONTRACTORS DESIGN

Where minimum labour intensity is specified by the design the contractor is expected to use their initiative to identify additional activities that can be done labour-intensively in order to comply with the set minimum labour intensity target.

15 PAYMENT OF LABOUR INTENSIVE ITEMS

Payment for items which are designated to be constructed labour-intensively (either in this schedule or in the scope of works) will not be made unless they are constructed using labourintensive methods. Any unauthorised use of plant to carry out work, which was to be done labourintensively will not be condoned, and any works so constructed will not be certified for payment.

FENCING OF IKAGELENG CEMETERY WARD 15
In the
RAMOTSHERE MOILOA LOCAL MUNICIPALITY
Of the North West Province

BID NO: RMLM SCM:2025/2026:COMM-05B

Bill of Quantities



RAMOTSHERE MOILOA LOCAL MUNICIPALITY					
FENCING OF IKAGELENG CEMETRY					
PROJECT NO.					
ITEM	DESCRIPTION	UNIT	QTY	RATE	AMOUNT
NO					R C
1	FIXED -CHARGE ITEMS				
1.1	Contractual requirements	Sum			
1.2	<u>Establish Facilities on Site</u>				
	a) Name Boards	No	1.0		
	b) Facilities for Contractor	Sum			
	Other fixed charge obligations	Sum			
2	HEALTH AND SAFETY				
2.1	Preparation of health and safety plan, training, PPE & other health and safety fixed-charge obligations	Sum			
3	TIME-RELATED ITEMS				
3.1	Contractual requirements	Month	3.0		
3.2	<u>Operate and maintain facilities on the site</u>				

3.2.1	a) Name boards	No	1.0		
3.2.2	b) Facilities for Contractor	Month	3.0		
3.2.3	Supervision for duration of the construction	Month	3.0		
3.2.4	Community Liaison Officer and PSC allowance	PC Sum			45,000.00
3.2.5	Handling cost and profit in respect of 3.2.4	%			

4	HEALTH AND SAFETY				
4.1	Preparation of health and safety plan, training, PPE & other health				
	health and safety fixed-charge obligations.	Month	3.0		
TOTAL CARRIED FORWARD					
ITEM	DESCRIPTION	UNIT	QTY	RATE	AMOUNT
NO					R C
5	<u>CONSTRUCTION ITEMS</u>				
5.1	Concrete Palisade Fencing				
5.1.1	Supply and Erect 2.50m height Reinforced Concrete Palisade with Steel SABS. The concrete strength to be 25mpa				
	Completed with all necessary fittings. As per drawings	m	1200		
5.2	Gate and Accessories				
		Sum	1.0	30 000	30 000

5.2.1	Supply and Intallation of 2.4 metres high and 5m width Steel Gates with all necessary fittings. Covered with mental sheet painted in black.				
5.2.2	Profit and Attendance	%			
TOTAL CARRIED FORWARD					
ITEM NO					
6	<u>SUMMARY</u>				
1	Preliminary and General				
2	Construction items				
				Sub-Total A	
Plus	Contigencies 10% of Sub Total A				
Plus	Value added Tax at 15% of Sub Total B			Sub-Total B	
				TOTAL AMOUNT	

